

3 1/4" Smart Cassette with Bi-Directional Motor

Tube & Fabric Deduction

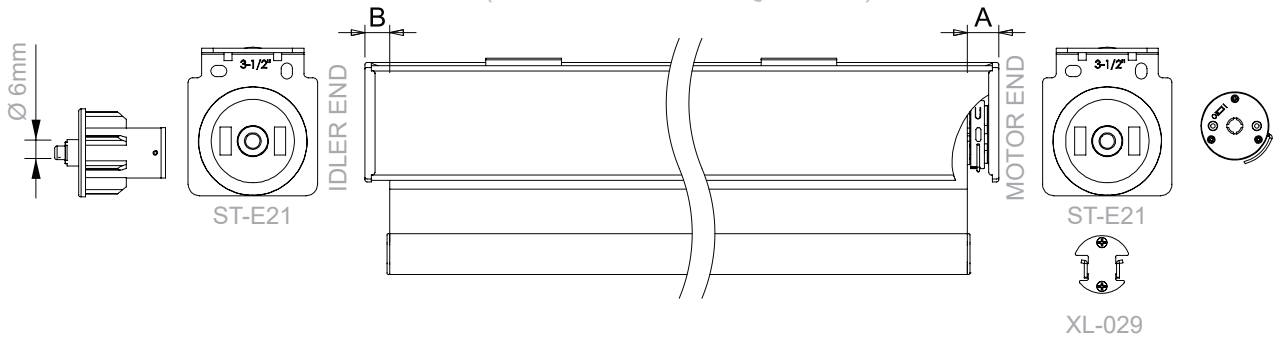

3 1/4" SMART CASSETTE SYSTEM USING XL BRACKET (XL ADAPTOR REQUIRED)



DEDUCTIONS

3 1/4" SMART CASSETTE SYSTEM USING SP BRACKET

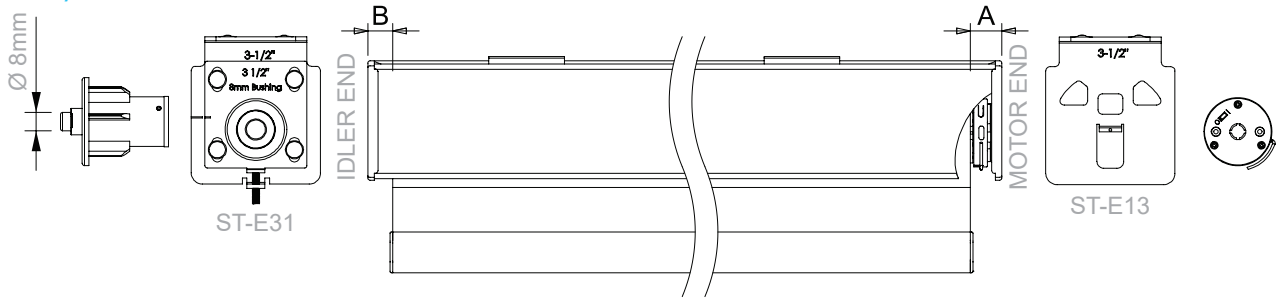

3 1/4" Smart Cassette using RS Bracket

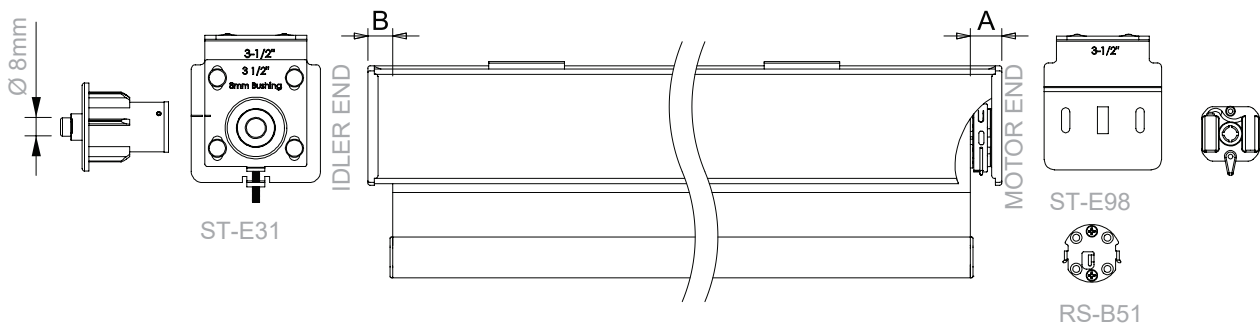

ZM001 & ZM002 Li-ion Bi Directional Motor

Bracket & Idler	Item #	A	B	d	End Cap
3 1/4" Smart Cassette XL	ST-E21+ST-E21 XL-A0*/B0*/C0*	inches 0.82 mm 20.8	0.65 16.4	1.46 37.2	0.17 4.2
3 1/4" Smart Casse. SP	ST-E31+ST-E13 XL-A0*/B0*/C0*	inches 0.61 mm 15.4	0.65 16.4	1.25 31.8	0.17 4.2
3 1/4" Smart Casse. RS	ST-E98+ST-E31	inches 0.82 mm 20.6	0.65 16.4	1.46 37	0.17 4.2

NOTE: The above chart is to be used for guideline purposes only



3 1/4" Smart Cassette with Switch Control Wand Motor

Tube & Fabric Deduction

3 1/4" SMART CASSETTE SYSTEM USING XL BRACKET (XL ADAPTOR REQUIRED)

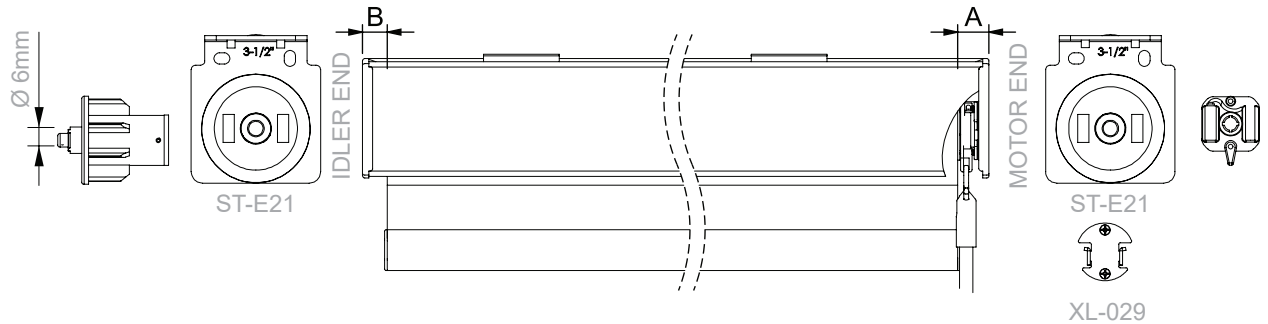

3 1/4" SMART CASSETTE SYSTEM USING SP BRACKET

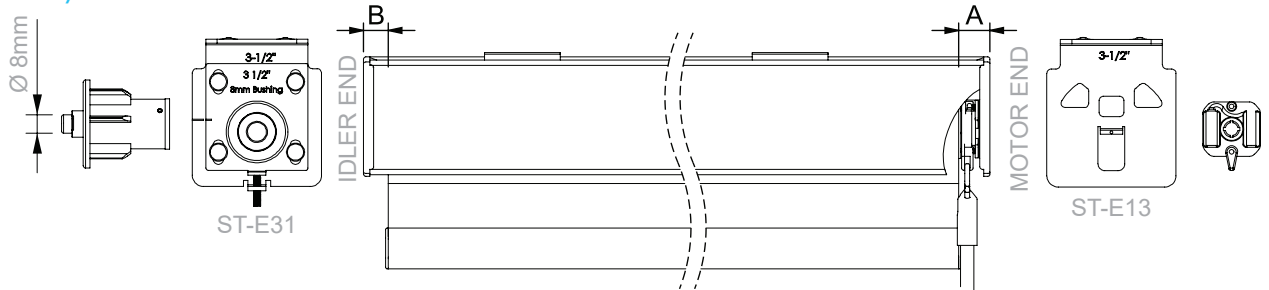

3 1/4" Smart Cassette using RS Bracket

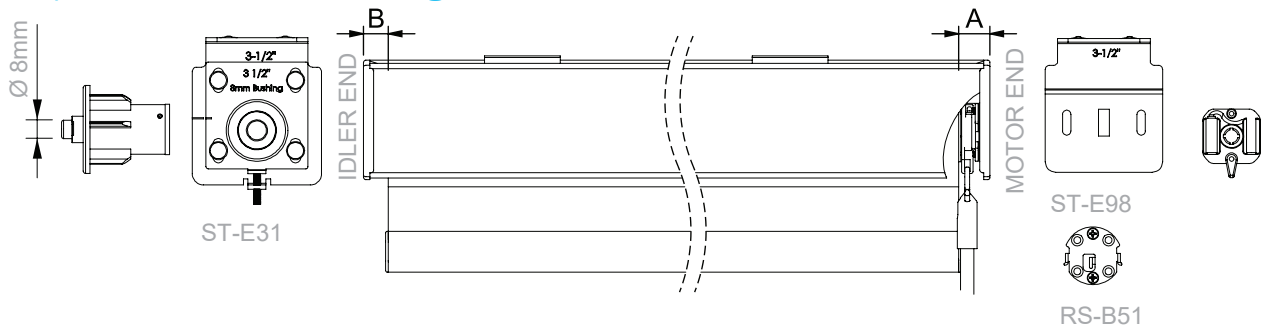

ZM001 & ZM002 Li-ion Bi Directonal Motor

Bracket & Idler	Item #		A	B	d	End Cap
3 1/4" Smart Cassette XL	ST-E21+ST-E21 XL-A0*/B0*/C0*	inches	0.82	0.65	1.46	0.17
		mm	20.8	16.4	37.2	4.2
3 1/4" Smart Casse. SP	ST-E31+ST-E13 XL-A0*/B0*/C0*	inches	0.61	0.65	1.25	0.17
		mm	15.4	16.4	31.8	4.2
3 1/4" Smart Casse. RS	ST-E98+ST-E31	inches	0.82	0.65	1.46	0.17
		mm	20.6	16.4	37	4.2

NOTE: The above chart is to be used for guideline purposes only