

# SONESSE ULTRA 50 AC/DC MOTOR

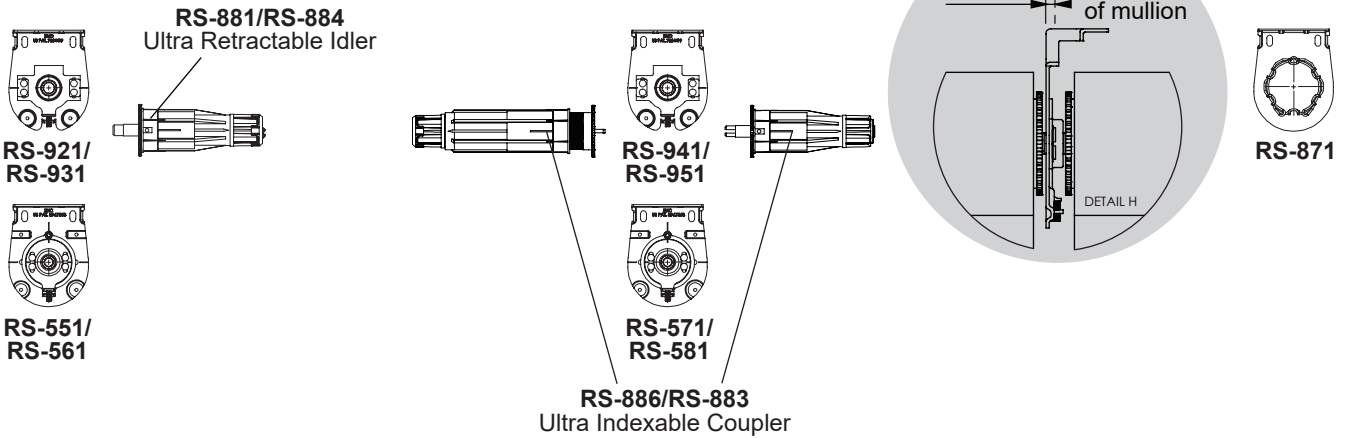

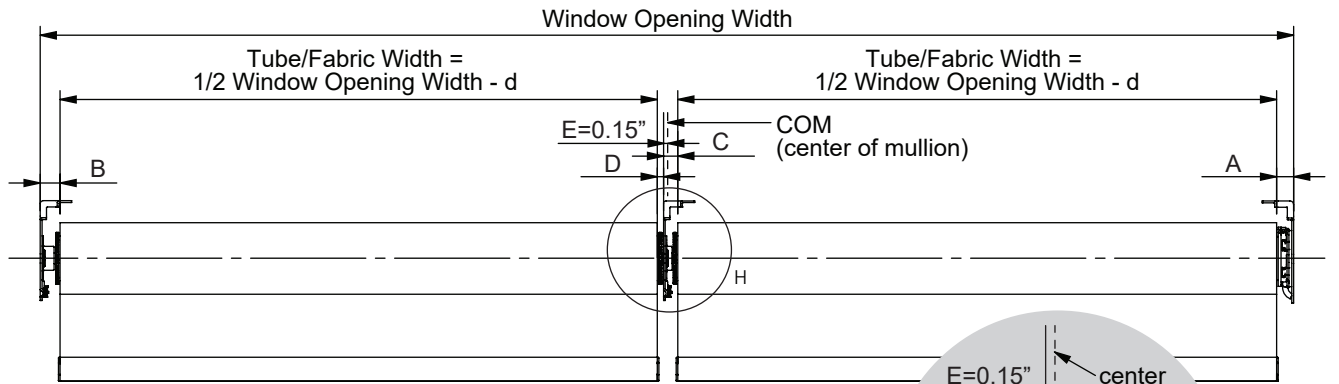

## Open Roll System Tube & Fabric Deduction (without End Cap)

For Somfy Sonesse 50AC Star Head Motor



### IDLER BRACKET OPTIONS



Tube	Crown	Unit	RS-921/931 + RS-881/884					RS-551/561 + RS-881/884						
			Light Gap		Deduction		Int Brk off COM	Light Gap		Deduction		Int Brk off COM		
			A	B	C	D	$d=1/2(A+B+C+D)$	$E=1/2(C-D+A-B)$	A	B	C	D	$d=1/2(A+B+C+D)$	$E=1/2(C-D+A-B)$
<b>RS-013</b> 	not needed	in	0.79	0.87	0.63	0.26	1.27	0.15	0.79	1.02	0.78	0.26	1.42	0.15
		mm	20.0	22.0	16.0	6.5	32.3	3.8	20.0	25.9	19.9	6.5	36.2	3.8
<b>RS-033</b> 	<b>RS-975</b> 	in	0.85	0.94	0.69	0.31	1.39	0.15	0.85	1.08	0.84	0.31	1.54	0.15
		mm	21.5	23.5	17.5	8.0	35.3	3.8	21.5	27.4	21.4	8.0	39.2	3.8
<b>RS-T66</b> 	<b>RS-984</b> 	in	0.88	0.96	0.72	0.35	1.46	0.15	0.88	1.11	0.88	0.35	1.61	0.15
		mm	22.4	24.4	18.4	8.9	37.1	3.8	22.4	28.3	22.3	8.9	41.0	3.8

**NOTE:**  
 1. Use this chart as a guideline only.  
 2. Deduction with 1~2mm tolerance.  
 3. End cap thickness is 1.8mm.