

SONESSE ULTRA 50 AC/DC MOTOR

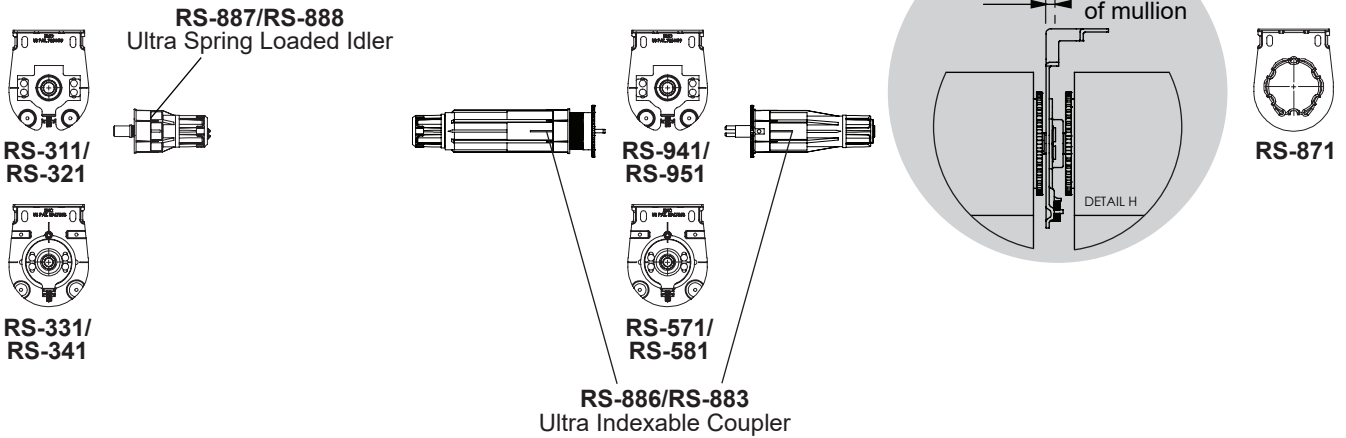

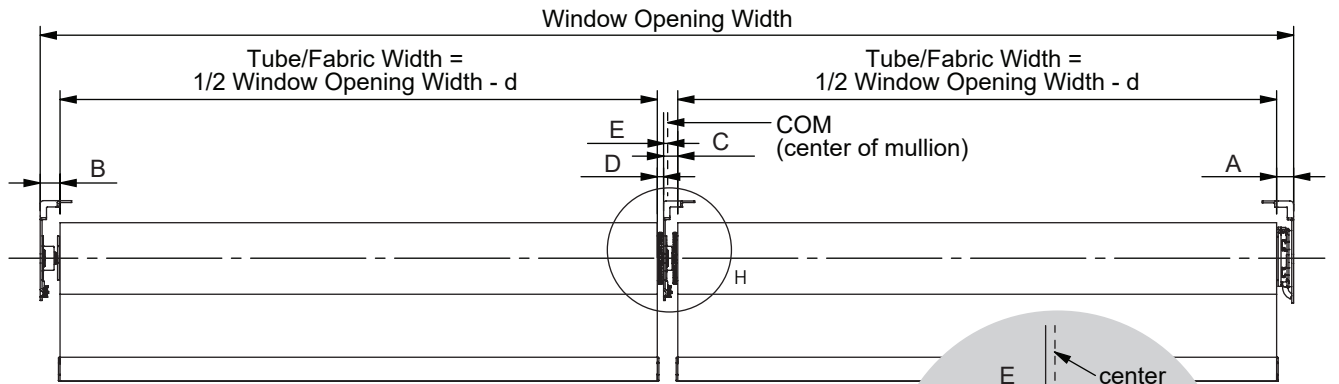

Open Roll System Tube & Fabric Deduction (without End Cap)

For Somfy Sonesse 50AC Star Head Motor



SWIVEL BALL BRACKET OPTIONS



Tube	Crown	Unit	RS-311/321 + RS-887/888						RS-331/341 + RS-887/888					
			Light Gap				Deduction	IB off COM	Light Gap				Deduction	IB off COM
			A	B	C	D	$d=1/2(A+B+C+D)$	$E=1/2(C-D)$	A	B	C	D	$d=1/2(A+B+C+D)$	$E=1/2(C-D)$
RS-013 	not needed	in	0.79	0.79	0.63	0.26	1.23	0.2	0.79	0.79	0.78	0.26	1.31	0.3
		mm	20.0	20.0	16.0	6.5	31.3	4.8	20.0	20.0	19.9	6.5	33.2	6.7
RS-033 	RS-975 	in	0.85	0.85	0.69	0.31	1.35	0.2	0.85	0.85	0.84	0.31	1.43	0.3
		mm	21.5	21.5	17.5	8.0	34.3	4.8	21.5	21.5	21.4	8.0	36.2	6.7
RS-T66 	RS-984 	in	0.88	0.88	0.72	0.35	1.42	0.2	0.88	0.88	0.88	0.35	1.50	0.3
		mm	22.4	22.4	18.4	8.9	36.1	4.8	22.4	22.4	22.3	8.9	38.0	6.7

- NOTE:
1. Use this chart as a guideline only.
 2. Deduction with 1~2mm tolerance.
 3. End cap thickness is 1.8mm.