

Fabric/Tube Deduction

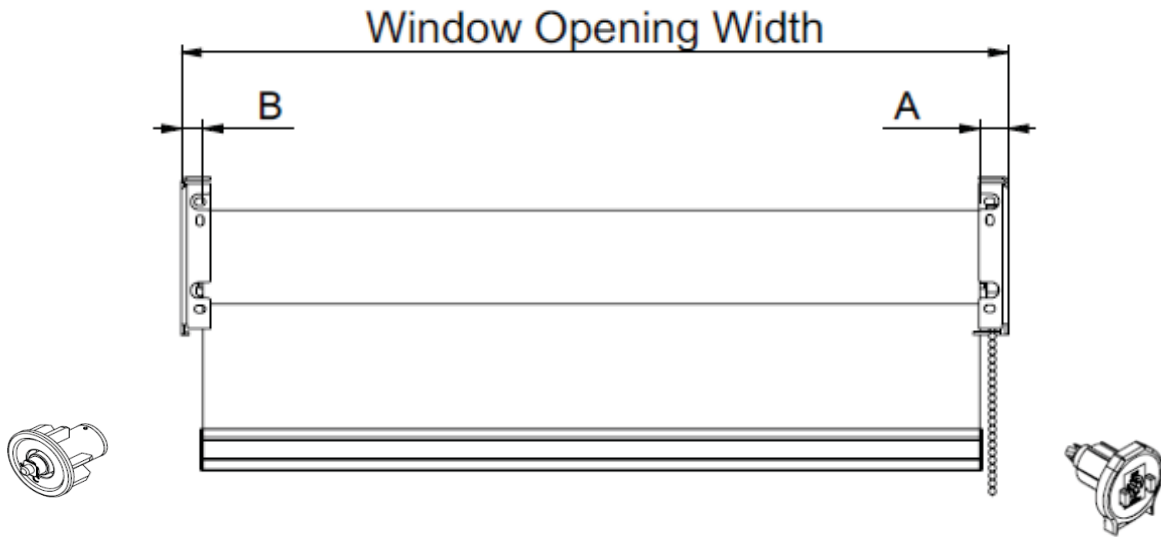



3"XL Fascia Bracket with XL12 Clutch

Single Band



Note:

1. Endcaps are not included in this drawing.
2. Endcap thickness is 1/8".

Tube	Clutch	Idler	A	B	Deduction
1 ¼" Tube (RS- T36) 	XL 12 Clutch (XL-4R6/4R0) (XL-5R6/05R/5R1~5)	XL Idle End (XL-E11/E15) (XL-A01/A05)	17mm (11/16 ")	14.5mm (9/16 ")	31.5mm (1 1/4 ")
1 ½" Tube (RS- T46) 					

Fabric/Tube Deduction



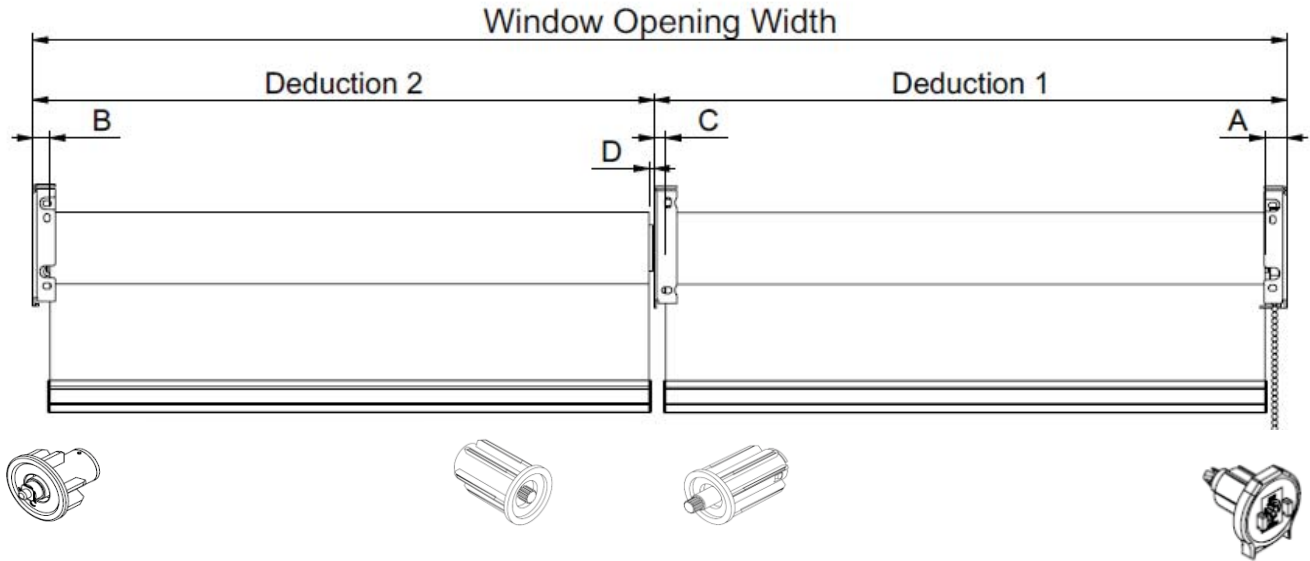

3"XL Fascia Bracket with XL12 Clutch

Multi Band-Intermediate



Note:

1. Endcaps are not included in this drawing.
2. Endcap thickness is 1/8".

Tube	Clutch	Inter. Idler	Idler	A	B	C	D	D1 (A+C)	D2 (B+D)
1 1/2" Tube (RS- T46) 	XL 12 Clutch (XL- 5R6/5R0/5R1~5) 	Inter.Idler (RS-WQ5, RS-WM2) 	XL Idle End (XL-A01/A05) 	17mm (11/16 ")	14.5mm (9/16 ")	9.5mm (3/8")	4.5mm (3/16 ")	26.5 mm (1 1/16")	19 mm (3/4")

Fabric/Tube Deduction

3"XL Fascia Bracket with XL12 Clutch

Multi Band-Center Support

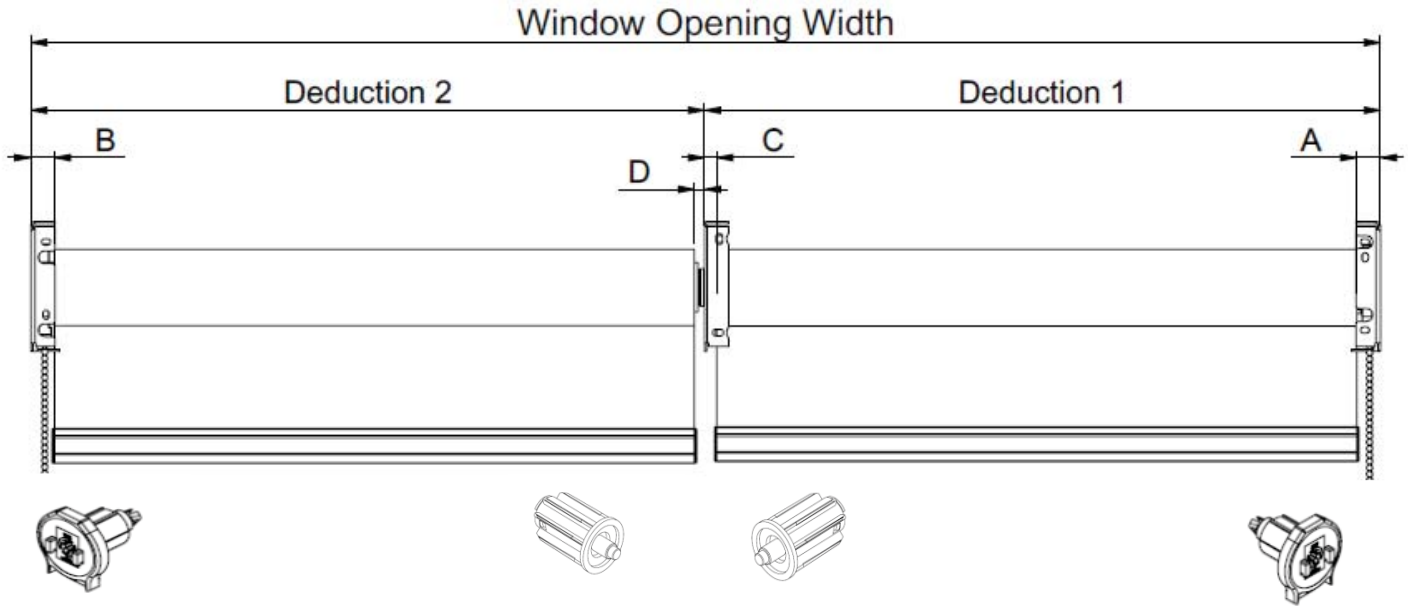

Note:

1. Endcaps are not included in this drawing.
2. Endcap thickness is 1/8".

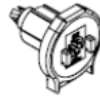
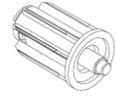
Tube	Clutch	Center Idler	A	B	C	D	D1 (A+C)	D2 (B+D)
1 1/2" Tube (RS- T46) 	XL 12 Clutch (XL-5R6/5R0/5R1~5) 	Center Idler (RS-WQ6) 	17mm (11/16 '')	17mm (11/16 '')	9.5mm (3/8 '')	8mm (5/16 '')	26.5 mm (1 1/16 '')	25 mm (1 '')